

2009 FIT - Ignition Coil and Spark Plug Removal/Installation

1. [Remove the under-cowl panel.](#)
2. Disconnect the ignition coil connectors, then remove the ignition coils.
3. [Remove the spark plugs and inspect them.](#)
4. Apply a small amount of anti-seize compound to the plug threads, and screw the plugs into the cylinder head, finger tight. Torque them to 18 N·m (1.8 kgf·m, 13lbf·ft).
5. Install the ignition coils in the reverse order of removal.

6 x 1.0 mm
9.8 N·m (1.0 kgf·m, 7.2 lbf·ft)

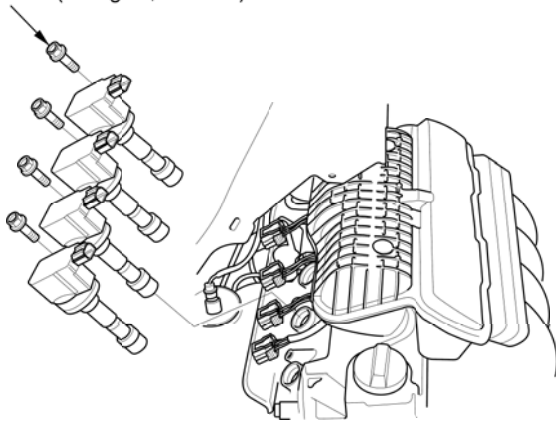

2009 FIT - Cowl Cover Replacement

Special Tools Required

- KTC Trim Tool Set SOJATP2014
 - *Available through the Honda Tool and Equipment Program; call 888-424-6857

Removal

NOTE:

- Put on gloves to protect your hands.
- Take care not to damage the body.
- Use the appropriate tool from the KTC trim tool set to avoid damage when removing components.

1. Close the hood.
2. Remove the driver's hood hinge cover (A) and the passenger's hood hinge cover (B).
 1. Carefully pull the bottom of the cover up to release the hooks (C) from the cowl cover (D).
 1. Release the rib (E) from the edge of the body.
 1. Carefully slide the cover up along the A-pillar to release it from the clip.
 1. Remove the clip from the body.
3. Open the hood.
4. [Remove the windshield wiper arms.](#)

Fastener Location

▷ : Clip, 1

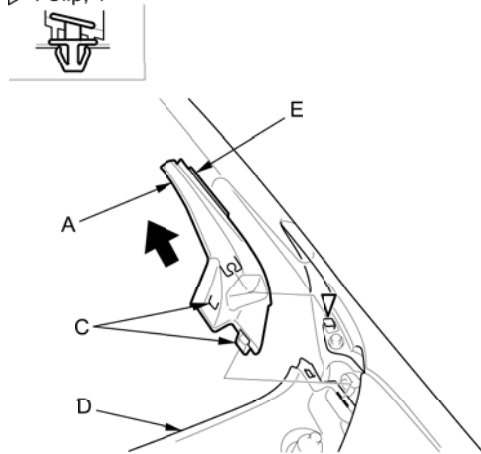

Fastener Location

▷ : Clip, 1

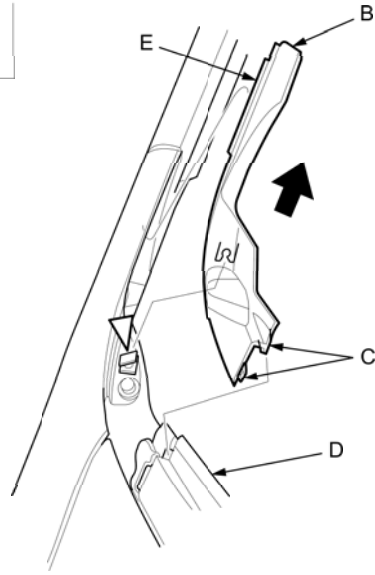

5. Detach the clips from the cowl cover with a clip remover, then disconnect the windshield washer tube (A).

Fastener Locations

▷ : Clip, 2

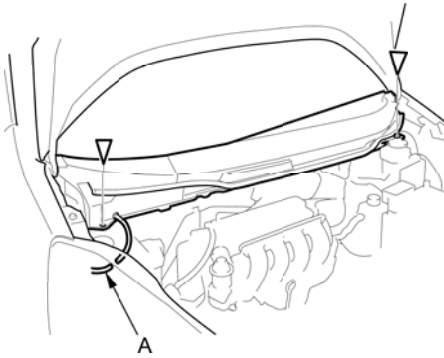

6. Detach the clips by carefully pulling the windshield side edge of the cowl cover (A) upward. Pull the cowl cover forward to release the front hooks (B) from the under-cowl panel (C), then remove the cover.
7. If the clips are damaged or stress-whitened, replace them with new ones.

Fastener Locations

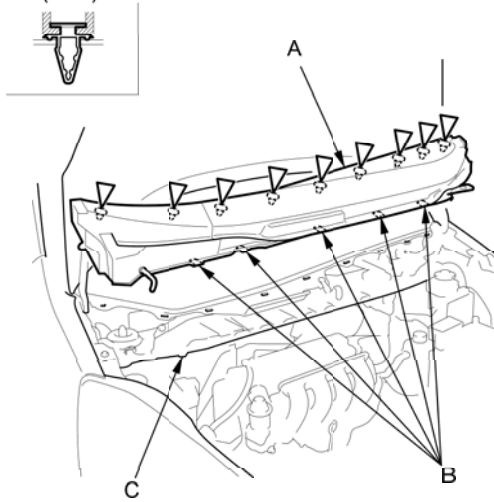
▷ : Clip, 9
(Blue)**Installation**

1. Install all of the front hooks (A) on the edge of the under-cowl panel (B), and fit the clips into the holes on the body, then push on the cowl cover (C) until the clips snap into place securely.

Fastener Locations

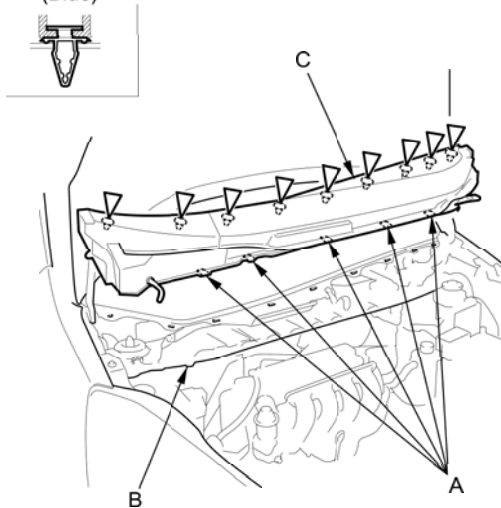
▷ : Clip, 9
(Blue)

2. Install the clips on the cowl cover, then connect the windshield washer tube (A) securely.
3. [Install the windshield wiper arms.](#)
4. Close the hood.

Fastener Locations

▷ : Clip, 2

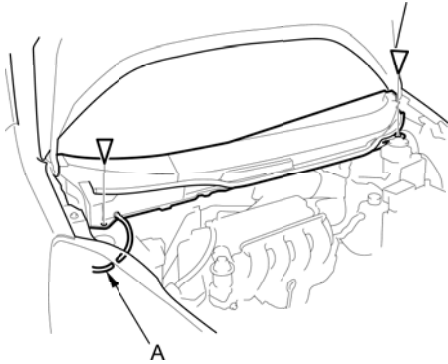
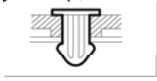

5. Install the clips (A) on both hood hinge covers (B). The passenger's hood hinge cover is shown; the driver's hood hinge cover is similar.

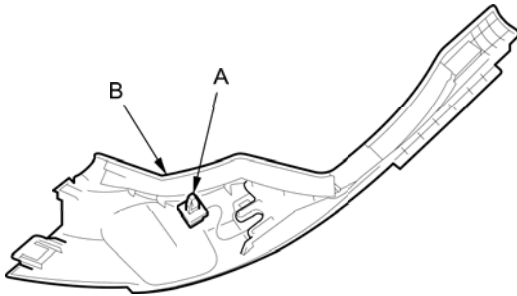

6. Install the hood hinge covers (A, B).
 1. Install the rib (C) to the edge of the body.
 1. Fit the clip and the hooks (D) into the holes in the body and the cowl cover (E), then push on the cover until they snap into place securely.

Fastener Location

▷ : Clip, 1

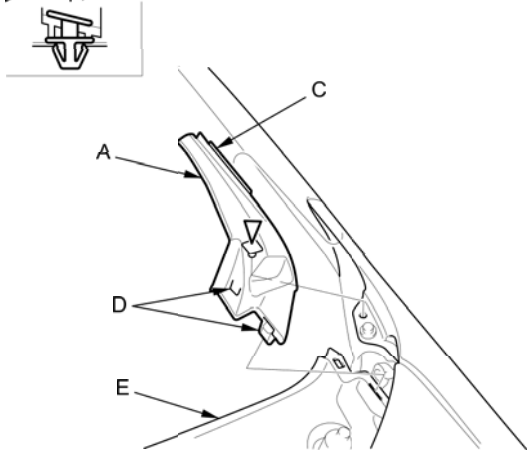

Fastener Location

▷ : Clip, 1

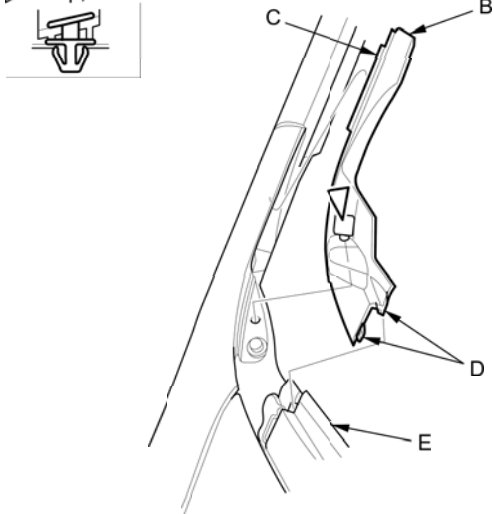

2009 FIT - Under-cowl Panel Replacement

NOTE: Take care not to scratch the body.

1. Remove these items:
 - [Windshield wiper arms](#)
 - [Cowl cover](#)
2. Remove the bolts, then remove the under-cowl panel (A).
3. Install the under-cowl panel in the reverse order of removal.

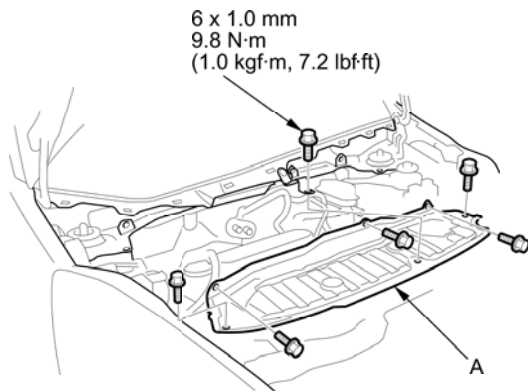

2009 FIT - Wiper Arm Replacement

NOTE: Set the wiper arms to the auto-stop position before removal and installation.

Windshield

NOTE: Always pull up the driver's side wiper blade first.

1. Remove the caps, the nuts, and the wiper arms.

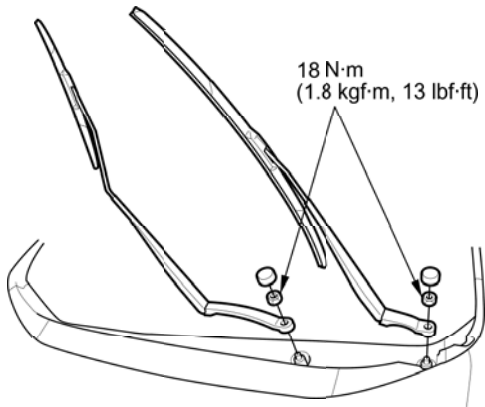

Rear Window

[Click here for an interactive version of this procedure.](#)

NOTE: Be careful not to damage the tailgate.

1. Remove the cover, the nut, and the wiper arm.

